

KEEL PLAN

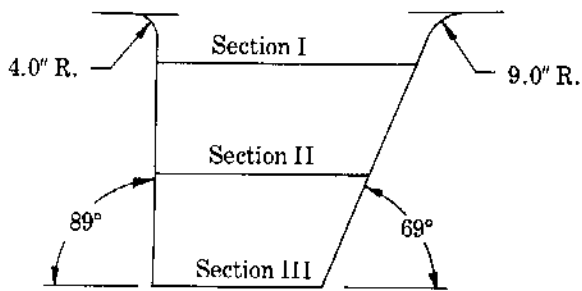

Front — down leading edge from hull
 Back — down trailing edge from hull
 Section chord length
 Leading edge radius

	I	II	III
Front	9.50	33.687	57.812
Back	8.656	31.156	53.687
Section chord length	52.00	42.437	33.812
Leading edge radius	0.375	0.312	0.250

KEEL SECTION OFFSETS

STATION ALONG (X)

Station	I	II	III
1/4	1.00	0.875	0.687
1/2	1.406	1.187	0.937
3/4	1.718	1.468	1.156
1	2.00	1.687	1.312
2	2.687	2.218	1.781
3	3.00	2.437	2.00
4	3.062	2.562	2.031
5	2.812	2.375	1.906
6	2.406	2.062	1.593
7	1.937	1.687	1.281
8	1.343	1.187	0.875
9	0.750	0.687	0.468
10	0.062	0.062	0.062

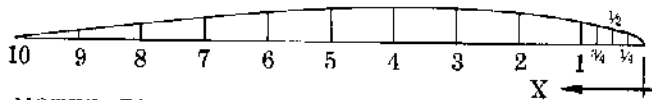

NOTES: Dimensions are in inches.
 These are the minimum faired dimensions at each station.

RUDDER PLAN

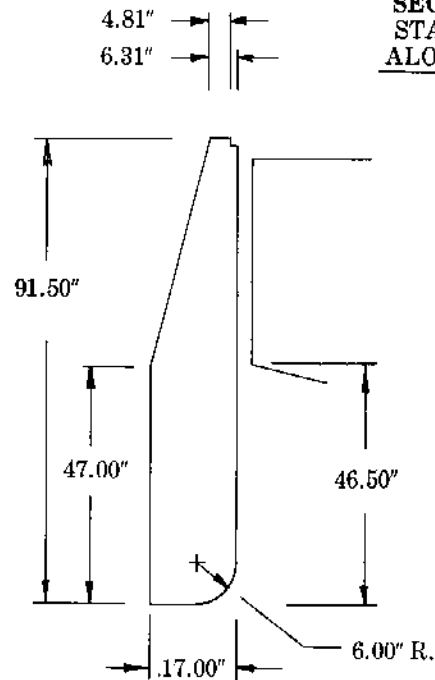

SECTION A OFFSETS

STATION SECTION ALONG (X) OFFSETS

Station	Offset
1/4	.325"
1/2	.531"
3/4	.625"
1	.718"
2	.968"
3	1.093"
4	1.125"
5	1.031"
6	.875"
7	.687"
8	.500"
9	.281"
10	.062"

Section A constant for 3'-11" from bottom of rudder

Station spacing = 1.703"

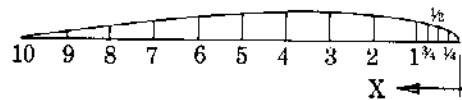

Leading edge .165" Radius
 Section A is perpendicular to the leading edge

NOTES: Dimensions are in inches.
 These are the minimum faired dimensions at each station.

DECK PLAN

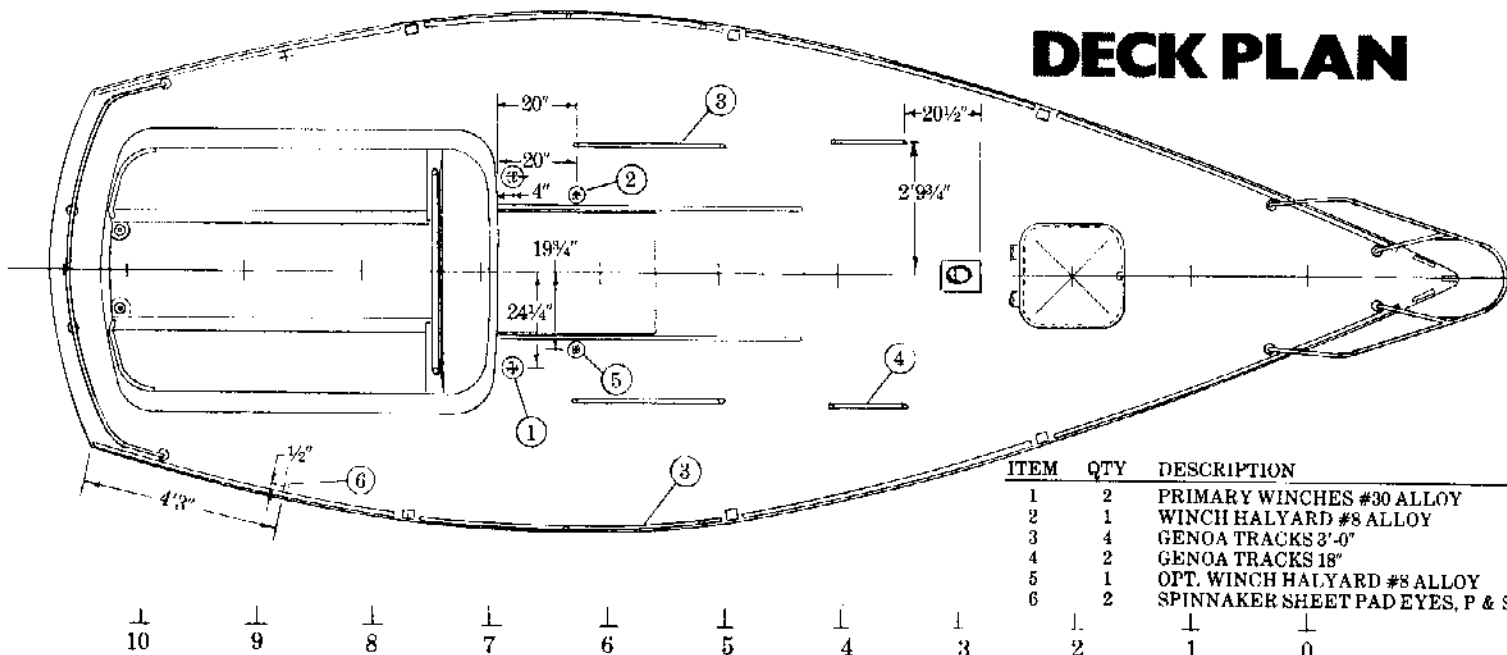

ITEM	QTY	DESCRIPTION
1	2	PRIMARY WINCHES #30 ALLOY
2	1	WINCH HALYARD #8 ALLOY
3	4	GENOA TRACKS 3'-0"
4	2	GENOA TRACKS 18"
5	1	OPT. WINCH HALYARD #8 ALLOY
6	2	SPINNAKER SHEET PAD EYES, P & S